

WINMAN SOLENOID VALVES

WVH0.S08 Valve Series



SAE Cartridge - 250 bar
NC Single Lock Pilot Operated - Poppet Type

Description

Solenoid operated, 2-way 2-positions, normally closed, piloted poppet type, screw-in cartridge valve.

Typically used as a blocking or load holding device for high pressure circuits. When the coil is de-energized, the SVH0.S08 acts as check valve allowing free flow from 1 to 2, while blocking from 2 to 1. When the coil is energized the poppet lifts and opens both the 2 to 1 and the 1 to 2 flow paths. The rigid design using a 1-piece body contributes to minimize the effect of eccentricities in cavity and provides great reliability. Low pressure drop thanks to optimized flow path.

Technical Features

All external surfaces are zinc plated and corrosion-proof.
All valve parts are made of high strength steel. Poppet is hardened and ground to ensure minimal wear and extended service life.
Coil seals protect the solenoid system.
Manual override options.
Industry SAE common cavity.

Performance Details

Note : For information about operating limits, please contact the factory.

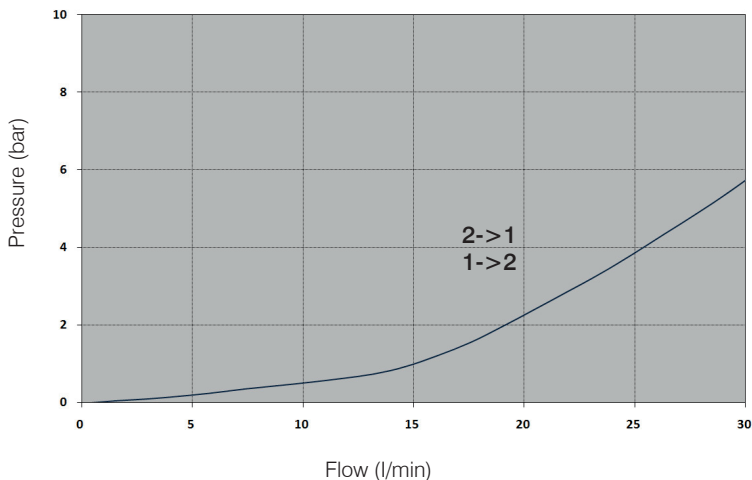

Symbols

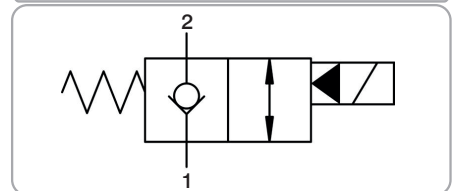

Technical Data

Maximum operating pressure: 250 bar
Maximum flow: 30 l/min
Internal leakage: max 5 drops/min @ 250 bar
Response time: Energized 30 ms,
De-energized 50 ms (typical 24V DC coil)
Temperature: -30°C to 110°C
Fluids: Mineral-based or synthetics with lubricating properties at viscosities of 7.4 to 420 cSt
Minimum pull-in voltage: 85% of nominal
Orientation: no restrictions
Installation torque: 40-45 Nm
Seal kit code: SK.030 and SK.027 (coil)
Weight: 0.120 kg
NOTE: The performance chart illustrates flow handling capacity in both directions (1 to 2 and 2 to 1, both energized).
P/Q curves are recorded at TOil = 40°C and 46 cSt

WINMAN SOLENOID VALVES

Cross Section

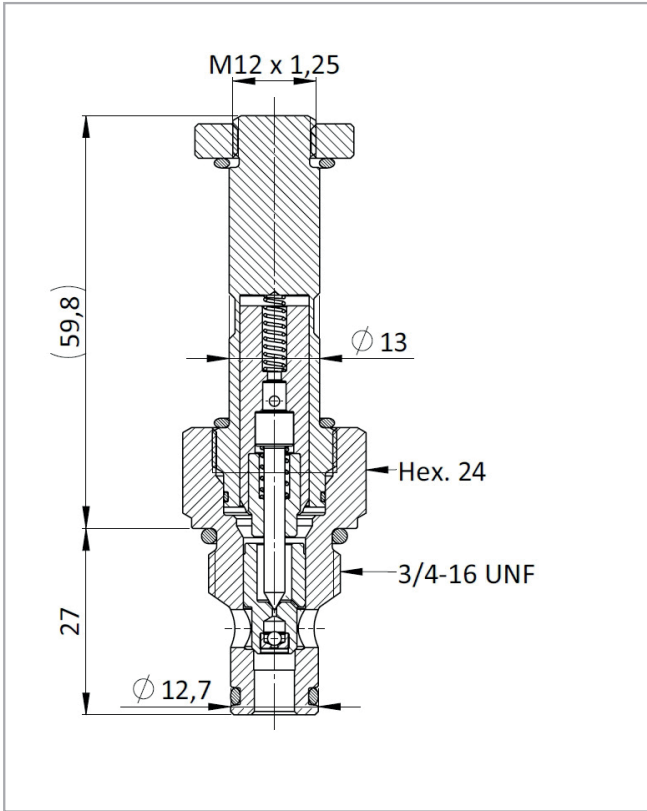

Cavity Details

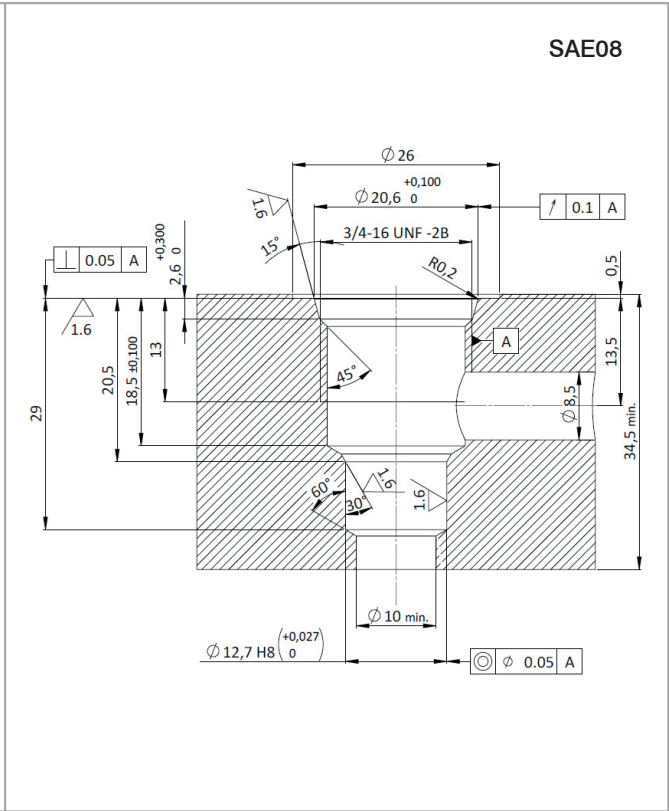

Ordering Code

W V H 0 • S 0 8 • 0 * • * 0 0

Valve basic code

Cavity

S08 = 3/4-16 UNF with Ø12,7 nose size
 Other available options:
 S09 = 3/4-16 UNF with Ø15,86 nose size
 M20 = M20 x 1,5 with Ø15 nose size

Filtration

Manual override

Marking

0=Standard factory marking
 Customized markings can be done upon request

Manual Override

Model Code	Type of override
0	No override
1	Screw
2	Push & Twist
6	Pull & Hold

Filtration

Model Code	Type of override
N	No filter
F	Standard filter (mesh size 280mm)

Customized filters can be done upon request

Coil



Use 18W coil to operate this valve.